

POWER

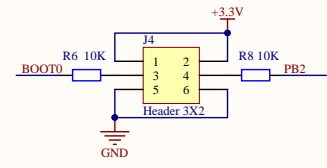

BOOT

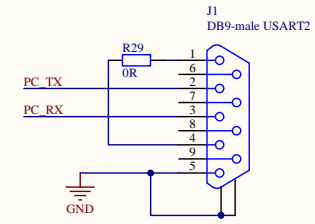

USART2

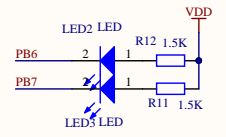
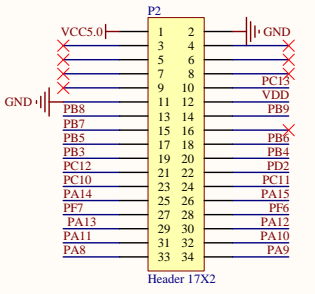
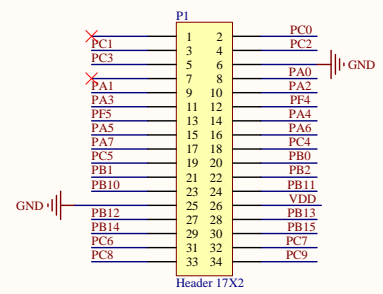

LED

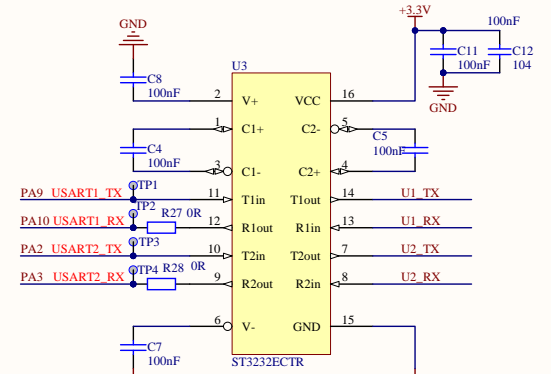

USART

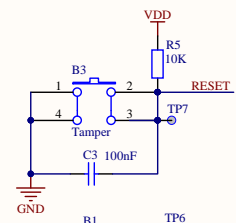
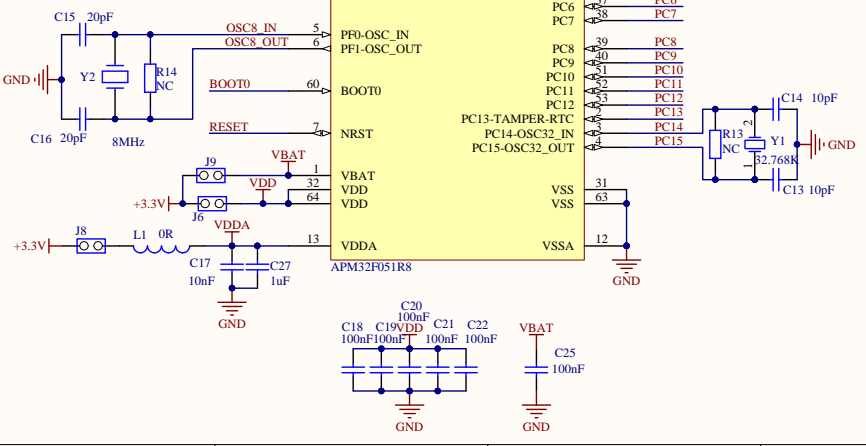
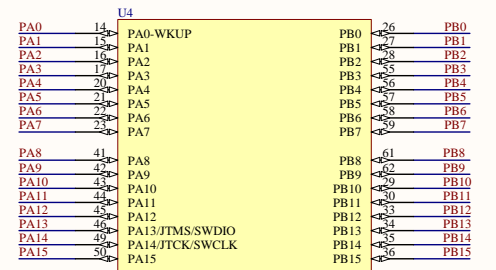

KEY

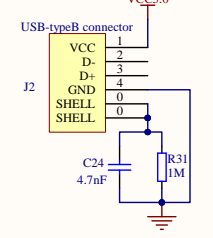
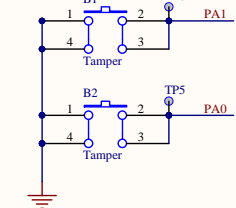

USB-5VIN

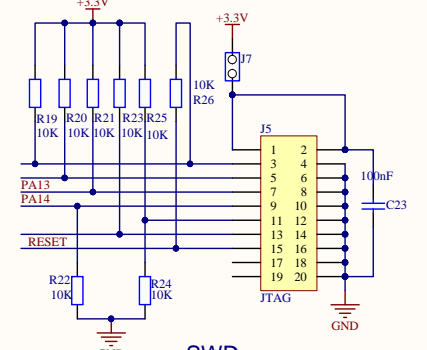

SWD

Company: Geehy Semiconductor Co.,Ltd.		
Title: APM32F051R8 MINIBOARD		
Revision: 1.0	Date: 20201022	Sheet 1 of 1